

## REQUIRED

### MAILBOX INFORMATION and SPECIFICATIONS (Sunset Drive Pines, a condominium)

1. Buyer acknowledges and hereby accepts to purchase their own individual mailbox by going to this website and following the Required Purchasing Specifications: <https://www.architecturalmailboxes.com/product/950020/>

Required Purchase Specifications:      Make: **Architectural Mailboxes**  
Model: **The Centennial**  
Item #: **950020B-10**

2. Mailbox location shall be in chronological order when installed on Sunset Drive.
3. Dimensions and Photo:

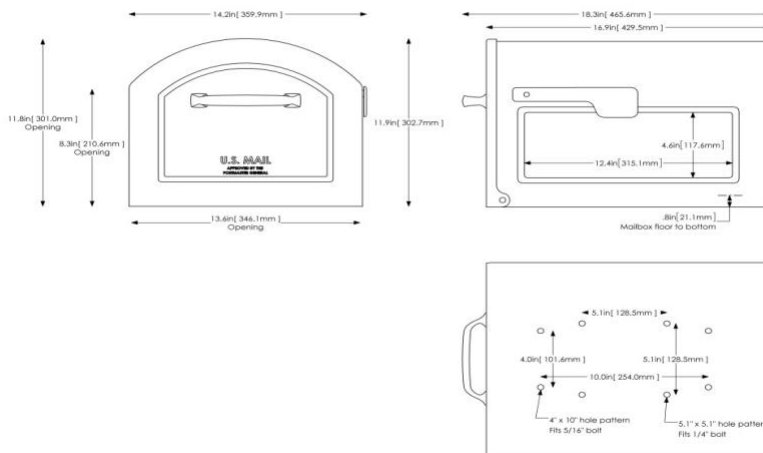

4. Should you need to purchase a post, contact Auburn Ridge 608.655.4801 or [info@auburnridge.com](mailto:info@auburnridge.com) <https://auburnridge.com/about/shawn-arnold/> The installation can be done by a local handyman.